

The background features a complex, low-poly geometric pattern in various shades of green, ranging from dark forest green to light sage green. A prominent white curved band sweeps across the middle of the page, separating the top and bottom green sections. The overall aesthetic is modern and technical.

API 6A FLANGES

API 6A - TYPE - 6B 13.8 MPA (2000 PSI)

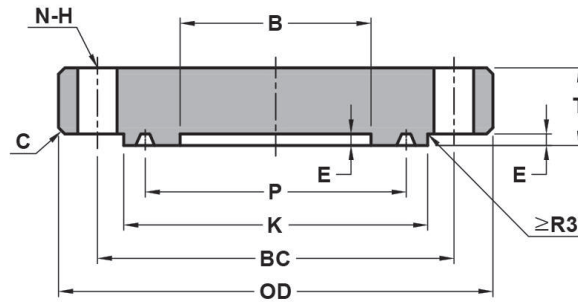

BLIND RTJ

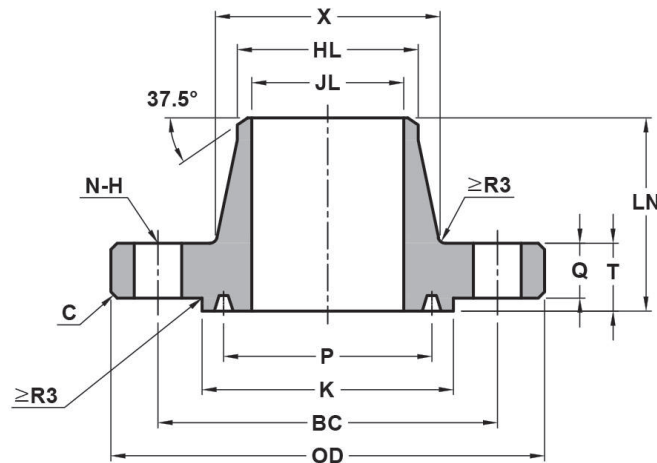

WELDING NECK RTJ

UNIT : mm

Size	B	OD	C (MAX.)	K	P	E	T	Q	X	BC	N	H	LN	HL	JL	Ring Number
																R or RX
2 1/16"	53.2	165	3	108	82.55	7.9	33.4	25.4	84	127	8	20	81	60.3	53.3	23
2 9/16"	65.9	190	3	127	101.60	7.9	36.6	28.6	100	149.2	8	23	88	73.0	63.5	26
3 1/8"	81.8	210	3	146	123.83	7.9	39.7	31.8	117	168.3	8	23	91	88.9	78.7	31
4 1/16"	108.7	275	3	175	149.23	7.9	46.1	38.1	152	215.9	8	26	110	114.3	103.1	37
5 1/8"	131.0	330	3	210	180.98	7.9	52.4	44.5	189	266.7	8	29	122	141.3	122.9	41
7 1/16"	181.8	355	6	241	211.15	7.9	55.6	47.6	222	292.1	12	29	126	168.3	147.1	45
9"	229.4	420	6	302	269.88	7.9	63.5	55.6	273	349.3	12	32	141	219.1	199.1	49
11"	280.2	510	6	356	323.85	7.9	71.5	63.5	343	431.8	16	35	160	273.0	248.4	53
13 5/8"	346.9	560	6	413	381.00	7.9	74.7	66.7	400	489	20	35	-	-	-	57
16 3/4"	426.2	685	6	508	469.90	7.9	84.2	76.2	495	603.2	20	42	-	-	-	65
21 1/4"	540.5	815	6	635	584.20	9.7	98.5	88.9	610	723.9	24	45	-	-	-	73

NOTE :

- 1) TOLERANCE ACCORDING TO API 6A - 20TH
- 2) RING GASKET ACCORDING TO API 6A-20TH

API 6A - TYPE - 6B 20.7 MPA (3000 PSI)

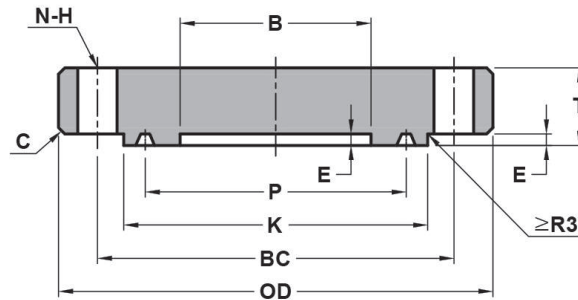

BLIND RTJ

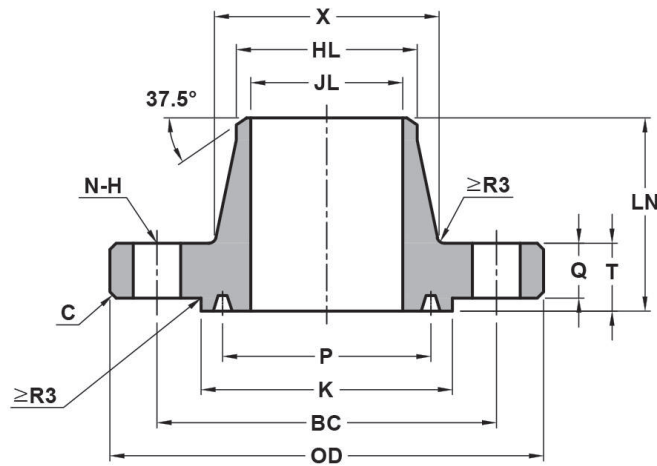

WELDING NECK RTJ

UNIT : mm

Size	B	OD	C (MAX.)	K	P	E	T	Q	X	BC	N	H	LN	HL	JL	Ring Number
																R or RX
2 1/16"	53.2	215	3	124	95.25	7.9	46.1	38.1	104.8	165.1	8	26	109.6	60.3	50.0	24
2 9/16"	65.9	245	3	137	107.95	7.9	49.3	41.3	123.8	190.5	8	29	112.7	73.0	59.7	27
3 1/8"	81.8	240	3	156	123.83	7.9	46.1	38.1	127.0	190.5	8	26	109.5	88.9	74.4	31
4 1/16"	108.7	290	3	181	149.23	7.9	52.4	44.4	158.8	235.0	8	32	122.2	114.3	98.0	37
5 1/8"	131.0	350	3	216	180.98	7.9	58.8	50.8	190.5	279.4	8	35	134.9	141.3	122.9	41
7 1/16"	181.8	380	6	241	211.15	7.9	63.5	55.6	235.0	317.5	12	32	147.6	168.3	147.1	45
9"	229.4	470	6	308	269.88	7.9	71.5	63.5	298.5	393.7	12	39	169.9	219.1	189.7	49
11"	280.2	545	6	362	323.85	7.9	77.8	69.9	368.3	469.9	16	39	192.1	273	237.2	53
13 5/8"	346.9	610	6	419	381.00	7.9	87.4	79.4	419.1	533.4	20	39	-	-	-	57
16 3/4"	426.2	705	6	524	469.90	11.2	100.1	88.9	508.0	616.0	20	45	-	-	-	66
20 3/4"	527.8	855	6	648	584.20	12.7	120.7	108	622.3	749.3	20	54	-	-	-	74

NOTE :

- 1) TOLERANCE ACCORDING TO API 6A - 20TH
- 2) RING GASKET ACCORDING TO API 6A-20TH

API 6A - TYPE - 6B 34.5 MPA (5000 PSI)

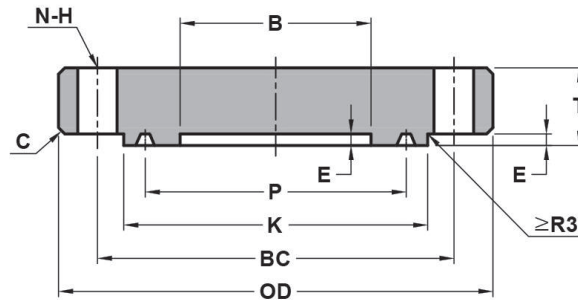

BLIND RTJ

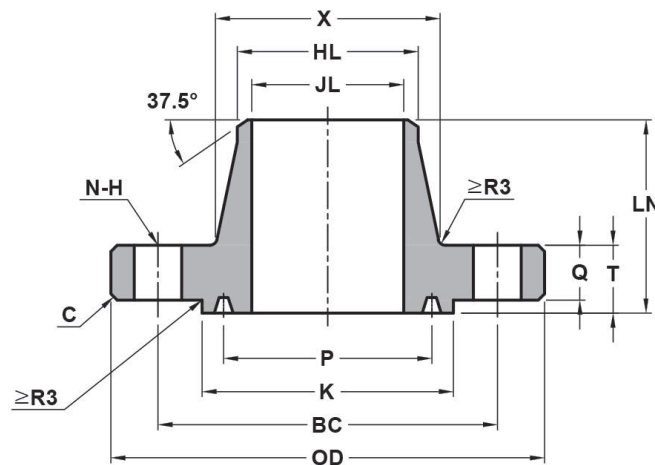

WELDING NECK RTJ

UNIT : mm

Size	B	OD	C (MAX.)	K	P	E	T	Q	X	BC	N	H	LN	HL	JL	Ring Number
																R or RX
2 1/16"	53.2	215	3	124	95.25	7.9	46.1	38.1	104.8	165.1	8	26	109.5	60.3	43.7	24
2 9/16"	65.9	245	3	137	107.95	7.9	49.3	41.3	123.8	190.5	8	29	112.7	73.0	54.9	27
3 1/8"	81.8	265	3	168	136.53	7.9	55.6	47.7	133.3	203.2	8	32	125.4	88.9	67.5	35
4 1/16"	108.7	310	3	194	161.93	7.9	62	54	161.9	241.3	8	35	131.8	114.3	88.1	39
5 1/8"	131.0	375	3	229	193.68	7.9	81	73.1	196.8	292.1	8	42	163.5	141.3	110.3	44
7 1/16"	181.8	395	6	248	211.15	9.7	92.1	82.6	228.6	317.5	12	39	181	168.3	132.6	46
9"	229.4	485	6	318	269.88	11.2	103.2	92.1	292.1	393.7	12	45	223.8	219.1	173.8	50
11"	280.2	585	6	371	323.85	11.2	119.1	108	368.3	482.6	12	51	265.1	273.1	216.7	54

NOTE :

- 1) TOLERANCE ACCORDING TO API 6A - 20TH
- 2) RING GASKET ACCORDING TO API 6A-20TH

API 6A - TYPE - 6BX 13.8 MPA (2000 PSI)

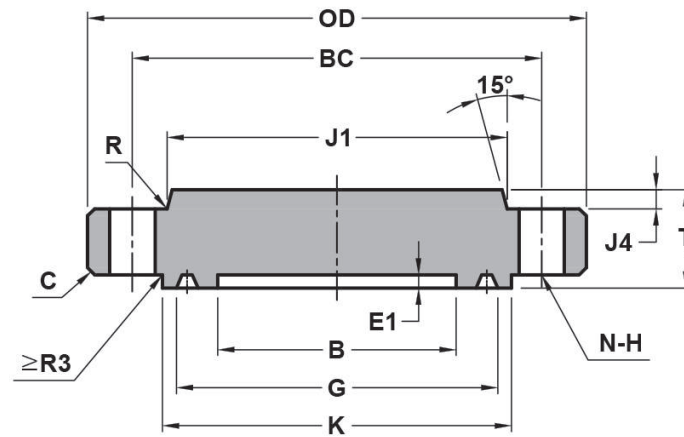

BLIND RTJ

UNIT : mm

Size	OD	C	E1	G	K	T	J1	J4	R	BC	N	H	Ring Number
													BX
26 3/4"	1040	6	21.4	768.33	805	126.3	835.8	9.7	16	952.5	20	48	167
30"	1120	6	23	862.3	908	134.2	931.9	17.5	16	1039.80	32	45	303

NOTE :

- 1) TOLERANCE ACCORDING TO API 6A-20TH
- 2) RING GASKET ACCORDING TO API 6A-20TH

API 6A - TYPE - 6BX 20.7 MPA (3000 PSI)

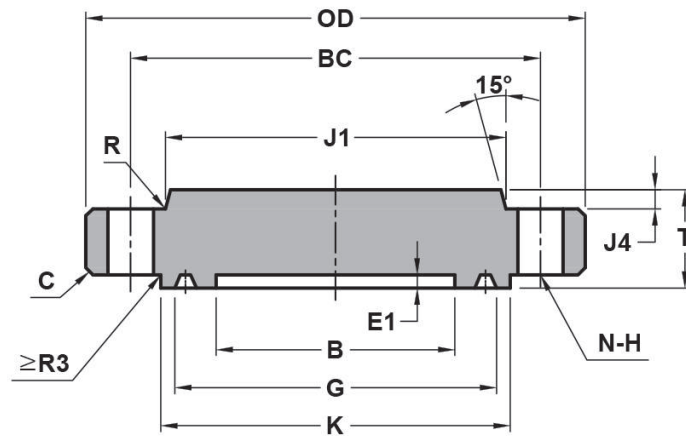

BLIND RTJ

UNIT : mm

Size	OD	C	E1	G	K	T	J1	J4	R	BC	N	H	Ring Number
													BX
26 3/4"	1100	6	21.4	774.22	832	161.2	870	0	16	1000.10	24	54	168
30"	1185	6	23	862.30	922	167.1	970	12.7	16	1090.60	32	51	303

NOTE :

- 1) TOLERANCE ACCORDING TO API 6A-20TH
- 2) RING GASKET ACCORDING TO API 6A-20TH

API 6A - TYPE - 6BX 34.5 MPA (5000 PSI)

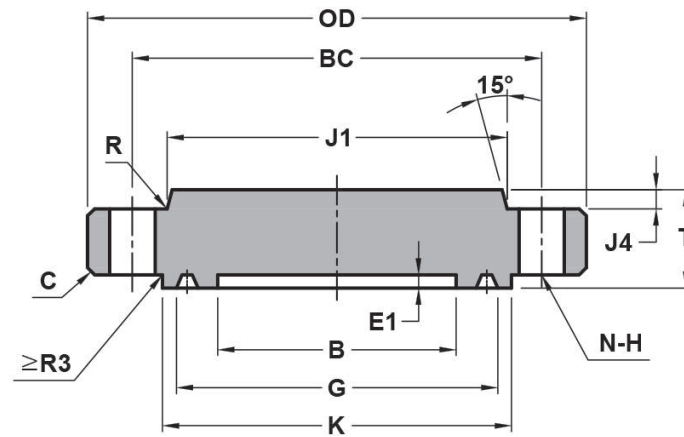

BLIND RTJ

UNIT : mm

Size	OD	C	E1	G	K	T	J1	J4	R	BC	N	H	Ring Number
													BX
13 5/8"	675	6	14.3	408.00	457	112.8	481.0	23.9	16	590.60	16	45	160
16 3/4"	770	6	8.3	478.33	535	130.2	555.6	17.5	19	676.30	16	51	162
18 3/4"	905	6	18.3	563.50	627	165.9	674.7	19.1	16	803.30	20	54	163
21 1/4"	990	6	19.1	632.56	702	181.0	758.8	22.4	18	885.80	24	54	165

NOTE :

- 1) TOLERANCE ACCORDING TO API 6A-20TH
- 2) RING GASKET ACCORDING TO API 6A-20TH

API 6A - TYPE - 6BX 69.0 MPA (10000 PSI)

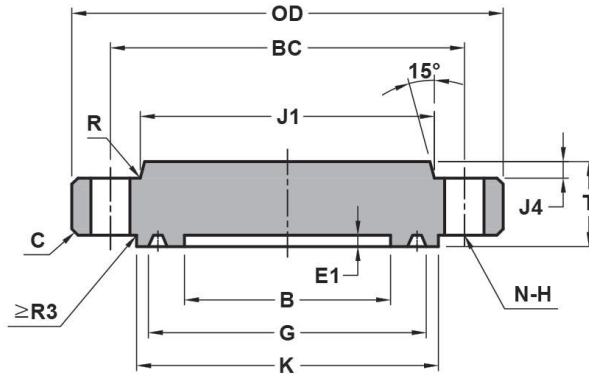

BLIND RTJ

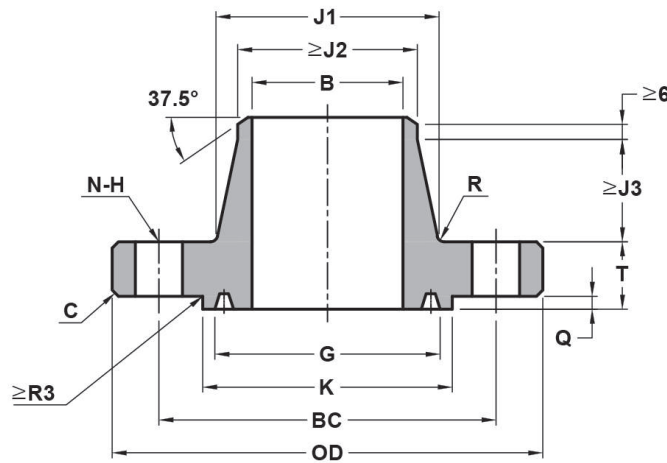

WELDING NECK RTJ

UNIT : mm

Size	B	OD	C	E1	Q (MAX.)	G	K	T	J1	J2	J3	J4	R	BC	N	H	Ring Number
																	BX
1 13/16"	46.8	185	3	-	5.56	77.77	105	42.1	88.9	65.1	48.5	-	10	146.10	8	23	151
2 1/16"	53.2	200	3	-	5.95	86.23	111	44.1	100.0	74.7	51.6	-	10	158.80	8	23	152
2 9/16"	65.9	230	3	-	6.75	102.77	132	51.2	120.7	92.1	57.2	-	10	184.20	8	26	153
3 1/16"	78.6	270	3	-	7.54	119.00	152	58.4	142.1	110.2	63.5	-	10	215.90	8	29	154
4 1/16"	104.0	315	3	-	8.33	150.62	185	70.3	182.6	146.1	73.1	-	10	258.80	8	32	155
5 1/8"	131.0	360	3	9.5	9.53	176.66	221	79.4	223.8	182.6	81.0	6.4	10	300.00	12	32	169
7 1/16"	180.2	480	6	11.1	11.11	241.83	302	103.2	301.6	254.0	95.3	9.7	16	403.20	12	42	156
9"	229.4	550	6	12.7	12.70	299.06	359	123.9	374.7	327.1	93.7	9.7	16	476.30	16	42	157
11"	280.2	655	6	14.3	14.29	357.23	429	141.3	450.9	400.1	103.2	14.2	16	565.20	16	48	158
13 5/8"	346.9	770	6	15.9	15.88	432.64	518	168.3	552.5	495.3	114.3	17.5	16	673.10	20	51	159
16 3/4"	426.2	870	6	8.3	8.33	478.33	576	168.3	655.6	601.7	76.2	30.2	19	776.30	24	51	162
18 3/4"	477.0	1040	6	18.3	18.26	577.90	697	223.1	752.5	674.7	155.6	25.4	16	925.50	24	61	164
21 1/4"	540.5	1145	6	19.1	19.05	647.88	781	241.3	847.7	762.0	165.1	31.8	21	1022.40	24	67	166

NOTE :

- 1) TOLERANCE ACCORDING TO API 6A-20TH
- 2) RING GASKET ACCORDING TO API 6A-20TH

API 6A - TYPE - 6BX 103.5 MPA (15000 PSI)

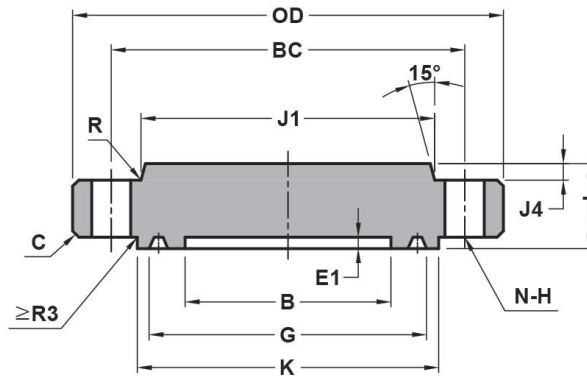

BLIND RTJ

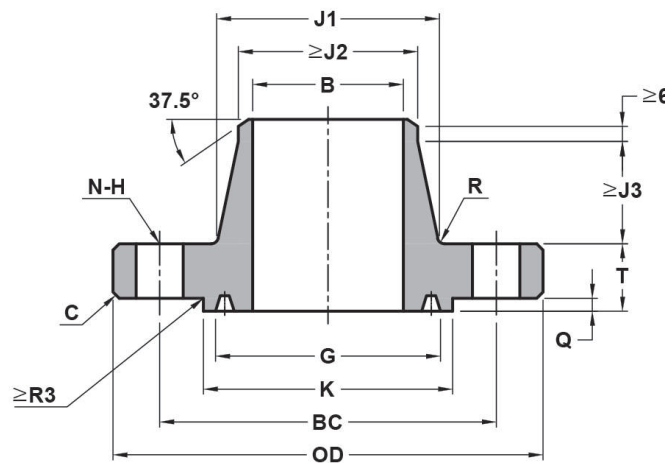

WELDING NECK RTJ

UNIT : mm

Size	B	OD	C	E1	Q (MAX.)	G	K	T	J1	J2	J3	J4	R	BC	N	H	Ring Number
																	BX
1 13/16"	46.8	210	3	-	5.56	77.77	106	45.3	97.6	71.4	47.6	-	10	160.3	8	26	151
2 1/16"	53.2	220	3	-	5.95	86.23	114	50.8	111.1	82.5	54.0	-	10	174.60	8	26	152
2 9/16"	65.9	255	3	-	6.75	102.77	133	57.2	128.6	100.0	57.1	-	10	200.00	8	29	153
3 1/16"	78.6	290	3	-	7.54	119.00	154	64.3	154.0	122.2	63.5	-	10	230.20	8	32	154
4 1/16"	104.0	360	3	-	8.33	150.62	194	78.6	195.3	158.7	73.0	-	10	290.50	8	39	155
5 1/8"	131.0	420	3	9.5	9.53	176.66	225	98.5	244.5	200.0	81.8	6.4	16	342.90	12	42	169
7 1/16"	180.2	505	6	11.1	11.11	241.83	305	119.1	325.4	276.2	92.1	7.9	16	428.60	16	42	156
9"	229.4	650	6	12.7	12.70	299.06	381	146.1	431.8	349.2	123.8	14.2	16	552.40	16	51	157
11"	280.2	815	6	14.3	14.29	357.23	454	187.4	584.2	427.0	235.7	12.7	16	711.20	20	54	158
13 5/8"	346.9	885	6	15.9	15.88	432.64	541	204.8	595.3	528.6	114.3	17.5	25	771.50	20	61	159
18 3/4"	477.0	1160	6	18.3	18.26	577.90	722	255.6	812.8	730.2	155.6	35.1	25	1016.00	20	80	164

NOTE :

- 1) TOLERANCE ACCORDING TO API 6A-20TH
- 2) RING GASKET ACCORDING TO API 6A-20TH

API 6A - TYPE - 6BX 138.0 MPA (20000 PSI)

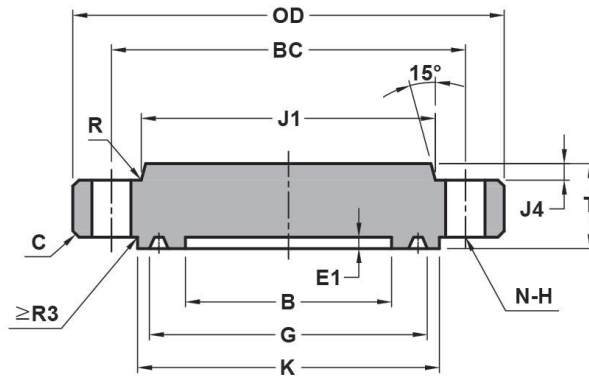

BLIND RTJ

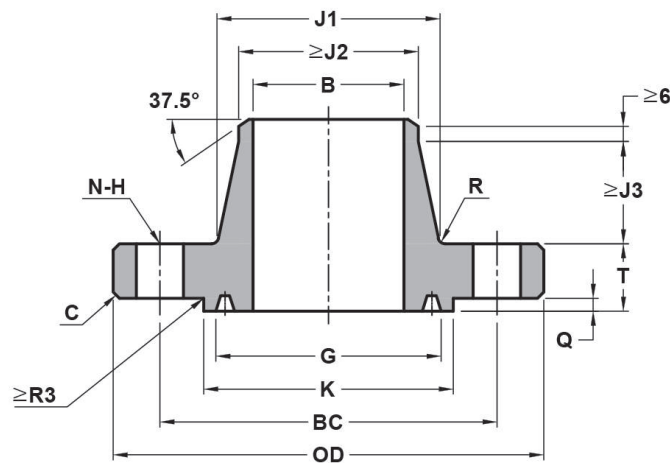

WELDING NECK RTJ

UNIT : mm

Size	B	OD	C	E1	Q (MAX.)	G	K	T	J1	J2	J3	J4	R	BC	N	H	Ring Number
																	BX
1 13/16"	46.8	255	3	-	5.56	77.77	117	63.5	133.4	109.5	49.2	-	10	203.20	8	29	151
2 1/16"	53.2	285	3	-	5.95	86.23	132	71.5	154.0	127.0	52.4	-	10	230.20	8	32	152
2 9/16"	65.9	325	3	-	6.75	102.77	151	79.4	173.0	144.5	58.7	-	10	261.90	8	35	153
3 1/16"	78.6	355	3	-	7.54	119.00	171	85.8	192.1	160.3	63.5	-	10	287.30	8	39	154
4 1/16"	104.0	445	3	-	8.33	150.62	219	106.4	242.9	206.4	73.0	-	10	357.20	8	48	155
7 1/16"	180.2	655	6	11.1	11.11	241.83	352	165.1	385.8	338.1	96.8	7.9	16	554.00	16	54	156
9"	229.4	805	6	12.7	12.7	299.06	441	204.8	481.0	428.6	107.9	6.4	25	685.80	16	67	157
11"	280.2	885	6	14.3	14.29	357.23	505	223.9	566.7	508.0	103.2	12.7	25	749.30	16	74	158
13 5/8"	346.9	1160	6	15.9	15.88	432.64	614	292.1	693.7	628.6	133.3	14.2	25	1016.00	20	80	159

NOTE :

- 1) TOLERANCE ACCORDING TO API 6A-20TH
- 2) RING GASKET ACCORDING TO API 6A-20TH